



# KEY ADVANTAGES

## DIESEL

The common rail turbo charged diesel engine provides high efficiency and torque. This results in powerful thrust and acceleration, with the capacity to carry heavy loads. The engine runs on a large variety of fuels: EN 590, ASTM D 975 No. 1 and No. 2, JIS KK 2204, F54 and F75.

## ENVIRONMENT

The use of highly refined, modern automotive-based engine technology significantly reduces the fuel consumption and provides for industry leading emission levels and subsequent minimized impact on the environment. The emission levels are approved by EPA TIER III, IMO TIER II (MARPOL VI TIER 2) and RCD.

## SAFETY

Diesel is a less flammable fuel and therefore safer to work with in hazardous environments. Robust design and quick shift capability leads to safe operation in fierce conditions. The OXE Diesel is designed to be safe in any environment.

## RANGE

Due to significantly lower fuel consumption than a comparable modern outboard the OXE Diesel offers the market with an

unprecedented range. Enabling users to go further and refilling from other vessels or marine based platform.

## REDUCED FUEL CONSUMPTION LEADS TO SIGNIFICANTLY INCREASED RANGE

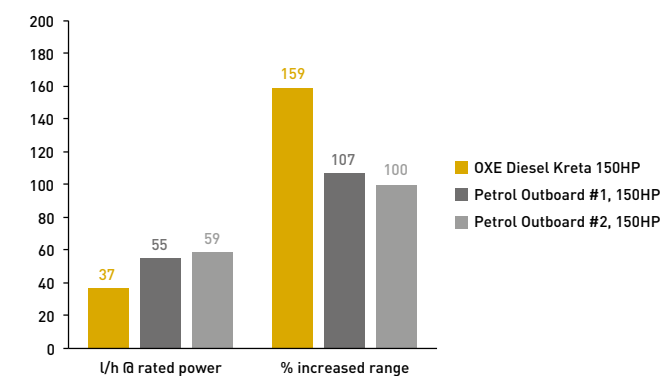

## MAINTENANCE

Easily accessible service points and a modular design create a user-friendly product. Interchangeable gear ratio allows for various operation. The reliable automotive powerhead keeps costs of maintenance and spare parts low. Longer service intervals ensure few disruptions in engine usage increasing operations profitability and productivity.



Kreta is the Swedish translation for the island of Crete. According to Greek legend, Poseidon brought forth from the ocean a snow-white bull for King Minos, confirming his absolute right to rule. Deeming the Cretan Bull too fine a specimen to sacrifice as commanded by the sea god, Minos kept it for himself.

Cimco Marine has taken this name and attributed it to our OXE Diesel Kreta. The Kreta presents superyacht tender boats a significant improvement and unparalleled mastery of range, fuel efficiency, maintenance, safety and maneuverability – as well as ease of refuelling directly from the yacht. It is designed for those who demand reliability at all times. OXE Diesel innovation cannot be compared to anything on the market today and fills a new segment within the marine industry.

From touring and passenger transfer to load carrier and tug – Kreta flexibility rules over all eventualities at sea.

**CIMCO**  
Endurance by Engineering

**Cimco Marine AB (Publ)**  
Metallgatan 17B, SE-262 72 Ängelholm, SWEDEN  
info@oxe-diesel.com, www.oxe-diesel.com



**OXE DIESEL OUTBOARD**

[www.oxe-diesel.com](http://www.oxe-diesel.com)

# OXE DIESEL KRETA

The OXE is the world's first **high-performance diesel outboard**. It combines the **reliability and endurance** of marine inboards with the **flexibility and agility** of outboard engines. It is the only outboard that complies with **EPA Tier-III, IMO Tier II and RCD emissions and environmental standards**. It is designed and built for commercial user after and is the perfect match for tender engines.

Cimco Marine AB, the manufacturer behind the engine, started this project with the mission to design the first high output diesel outboard, the keywords were **durability, endurance and performance**. These words are now embedded within The OXE Diesel KRETA.

The patented technology has enabled Cimco to design a **robust** drive unit that will **effectively** transfer **high torque** diesel power from the engine to the propeller. Combined with a modular layout, easily accessible service points, interchangeable gear ratios and proven diesel technology, ensures for a product fit for **commercial** use.

The OXE Diesel KRETA is designed with "single-fuel" directive in mind. It offers an effective and safe solution for yacht tenders where range, load carrying performance and running costs are significant factors.

The power head, a proven robust diesel engine developed by the GM group, is marinized and tested by the engineers at Cimco Marine AB. The compact design of the lower housing enables high efficiency and high-speed capability.

## FEATURES

- Diesel engine
- Low Speed Control
- Fuel economy
- CAN based helm control system
- Dual helm capability
- Joystick capability
- Robust modular design
- Low drag propulsion housing
- Directly replaceable with other outboards
- Quick shift capable



## OXE KRETA 150 HP TECHNICAL SPECIFICATION

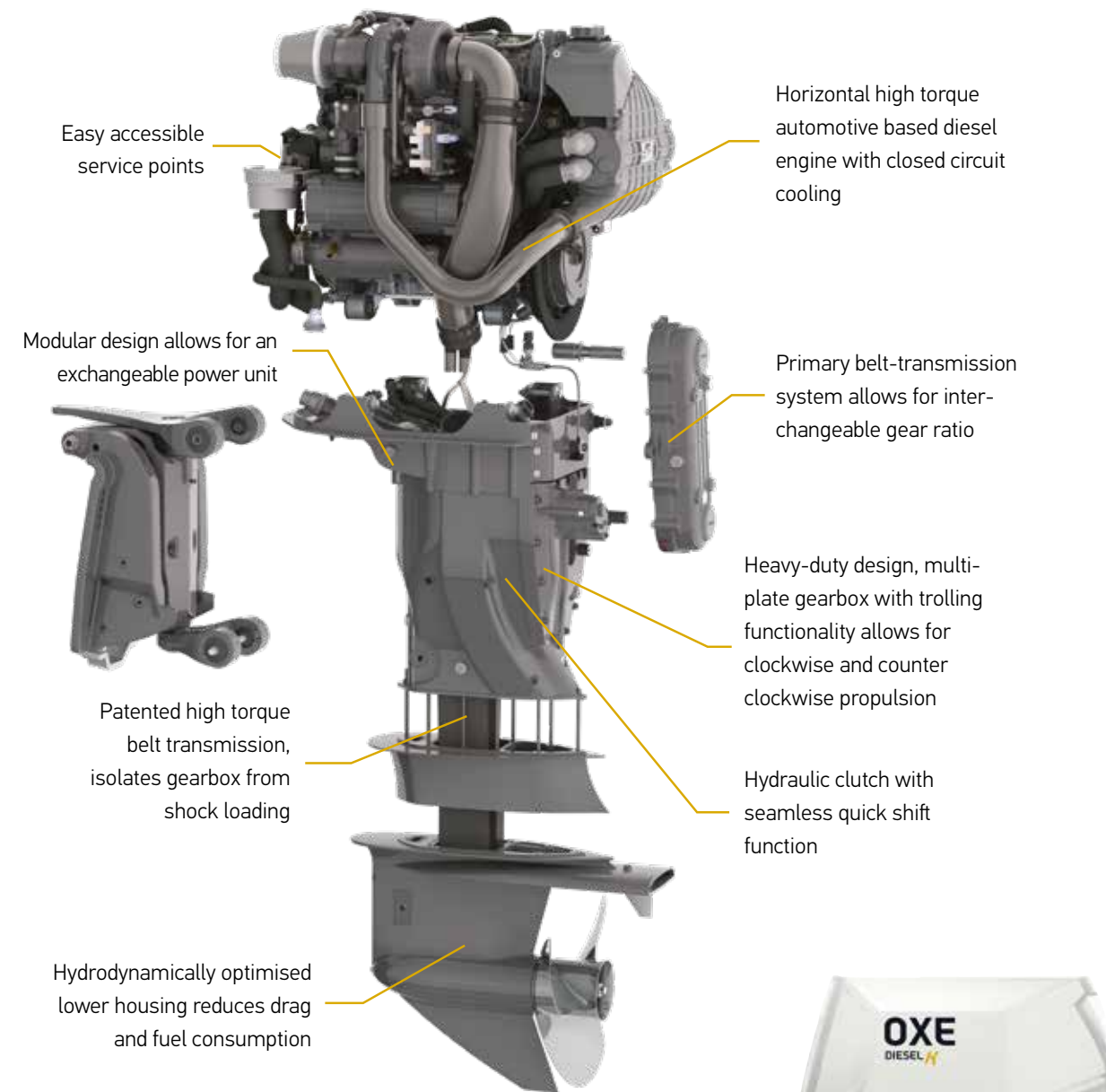

### OXE KRETA 150 HP TORQUE / POWER / FUEL CONSUMPTION

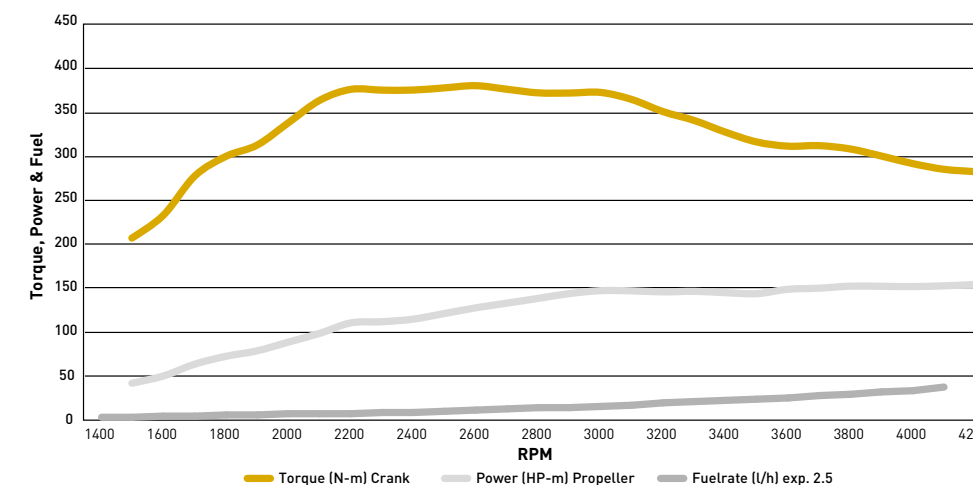

SIGNIFICANT OPERATIONAL BENEFIT

SERVICE INTERVAL **200 HRS/800 HRS**



### Technical data – OXE Diesel Kreta 150 HP

Engine type:	Diesel, L4	Alternator output:	130 Amp
Displacement:	2.0 L	Rig length:	25" or 33"
Intake:	Turbocharged, intercooled	Cooling:	Closed cooling circuit
Torque:	380 Nm at 2500 rpm	Starting:	Electric
Power:	150 HP at 4100 rpm	Steering:	Electronic Power Steering
Fuel:	Diesel	Shift:	CANbus, Electro-hydraulic
	EN 590, ASTM D 975 No.1	Clutch:	Hydraulic multi-friction plate
	No.2. JIS KK2204, F54 & F75	Gear ratios:	1.73:1 and 2.17:1
Weight:	350 kg	Dimensions (25" leg), LHW	994 x 1880 x 678 mm